

# D、DG 型卧式多级离心泵

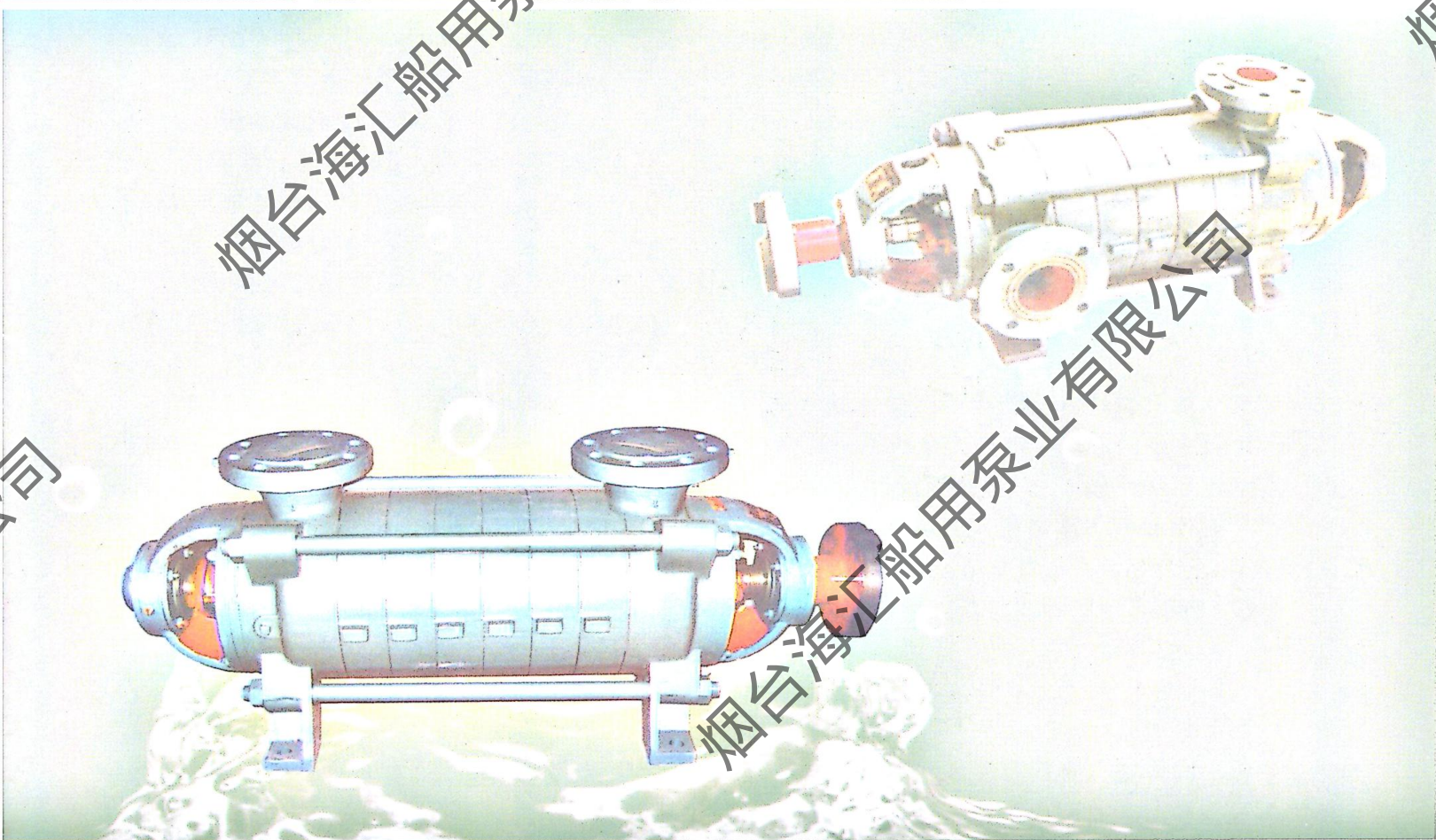

烟台海汇船用泵业有限公司

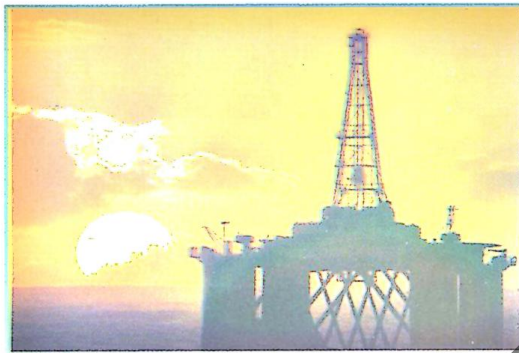
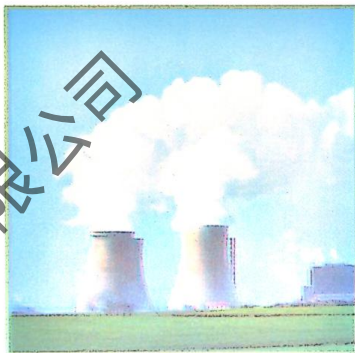

## 一、用途

1.1 D型和DC型泵是卧式多级离心泵。它适合于输送清水(含杂质量小于1%。颗粒度小于0.1毫米)及物理化学性质类似于清水的其它液体。

D型泵输送介质温度不大于80℃,它适用于矿山排水和工厂,城市供水等场合。

DG型泵输送介质温度不大于105℃,它适用于小型锅炉给水泵或输送类似的热热水等场合。

1.2 本型系列性能范围(按规定点):

流量: 6.3~450米<sup>3</sup>/时

扬程: 50~650米

1.3 型号意义说明

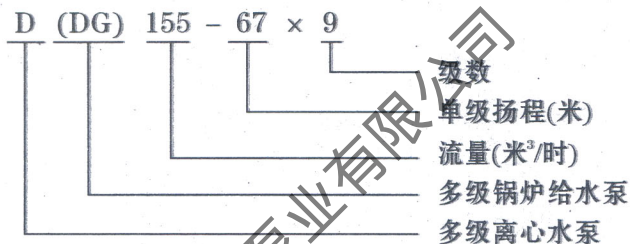

## 二、结构说明

本型泵主要由壳体部分,转子部分,平衡机构,轴承部分及密封部件组成。

### 1、壳体部分

壳体部分主要由吸入段、中段、吐出段、导叶、轴承体等用螺栓联接而成。泵的旋转方向,从驱动端看泵为顺时针方向旋转。

### 2、转子部分

转子部分主要由轴及装在轴上的叶轮,轴套,平衡盘等零件组成。轴上零件采用平键和轴套螺母紧固使之与轴成为一体,整个转子由两端轴承支承在泵壳体中。转子部件中叶轮数是根据泵级数而定的。

本型号泵在使用时,轴封一定要接水封水。采用的水封水分两种情况:一种是采用第一级叶轮的出水,另一种是引用外来水。凡表2中标明接水封水的均有引用外来水封水,未标明接水封水的均是采用第一级叶轮的出水作水封水。轴封的填料松紧程度必须适当,当液体能一滴一滴渗出为宜。当被输送的介质温度高于80℃时,必须向水冷填料压盖和轴封冷却室通入液却水,冷却水和引用外来的水封水均为常温清水,冷却水水压为1.5~3公斤/厘米<sup>2</sup>,水封水的压力要高于密封腔为0.5~1公斤/厘米<sup>2</sup>。各型泵的水封和轴封冷却室却水的管路接口位置不同,管路接口沿轴向的位置见泵结构图。

### 3、平衡机构

平衡机构由平衡环、平衡套、平衡盘及平衡管路等组成。

### 4、轴承部分

轴承部分主要由轴承体和轴承组成。本型泵轴承有滑动轴承和流通过两种。轴承均不承受轴向力,泵在运行中,转子部分在泵壳体中应能自由地轴向游动,不能采用向心球轴承,各型泵采用的轴承见表1。

### 5、泵的密封及冷却

壳体部分中的吸入段、中段、吐出段、导叶的结合面涂以二硫化钼润滑脂密封。

转子部分与固定部分之间靠密封环、导叶套、填料等密封。当密封环和导叶套的磨损程度已影响泵的工作和性能时,应及时更换。本型号在使用时,填料环的位置安放要正确,各型泵的填料及填料环的分布情况见表2。

图1 D型泵结构图

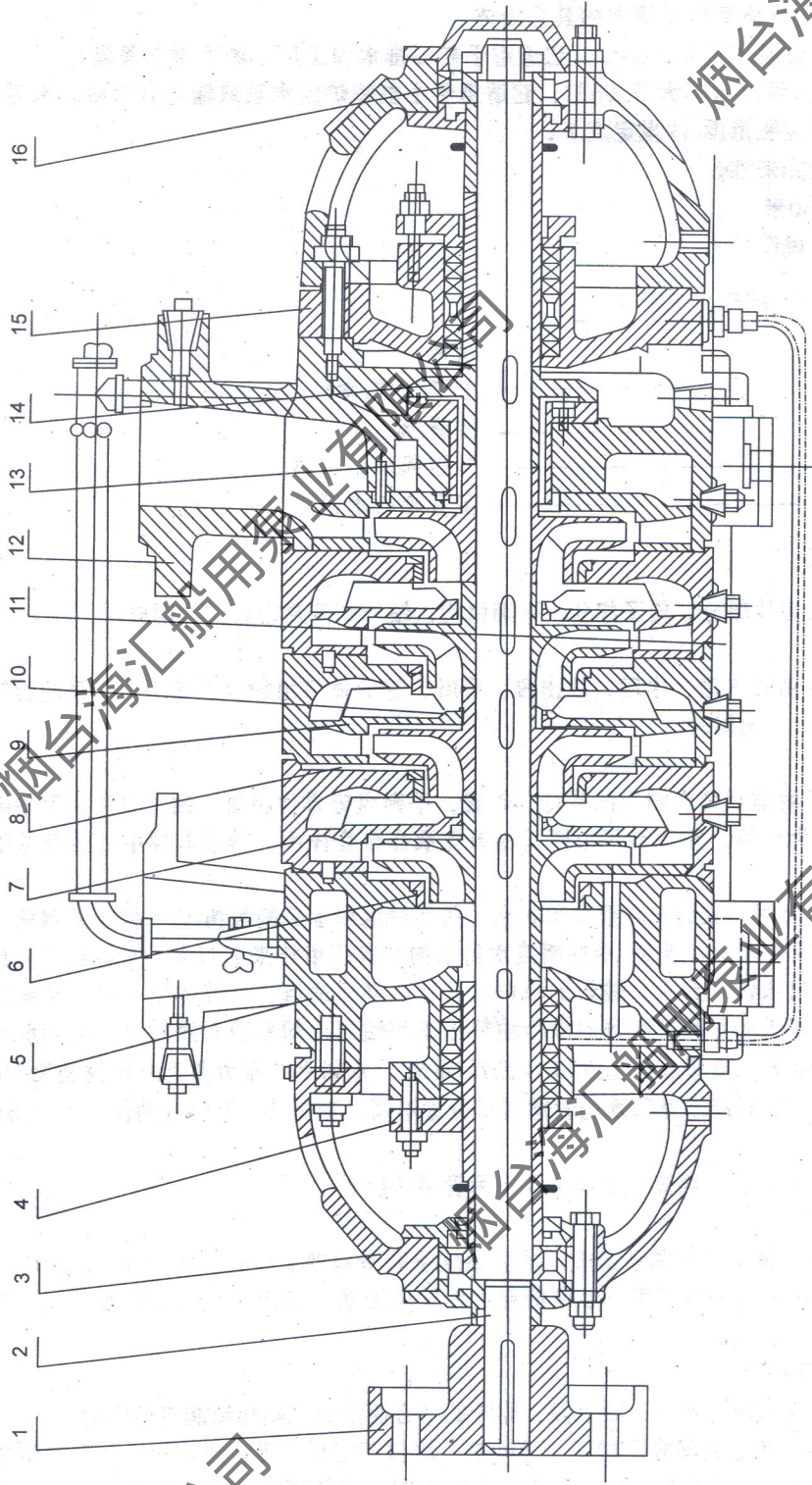

- 1、泵联轴器 2、轴 3、滚动轴承副 4、填料压盖 5、吸入段 6、密封环
- 7、中段 8、叶轮 9、导叶 10、导叶套 11、拉紧螺栓 12、吐出口
- 13、平衡套(环) 14、平衡盘 15、填料函 16、轴承



图2 DG型泵结构图

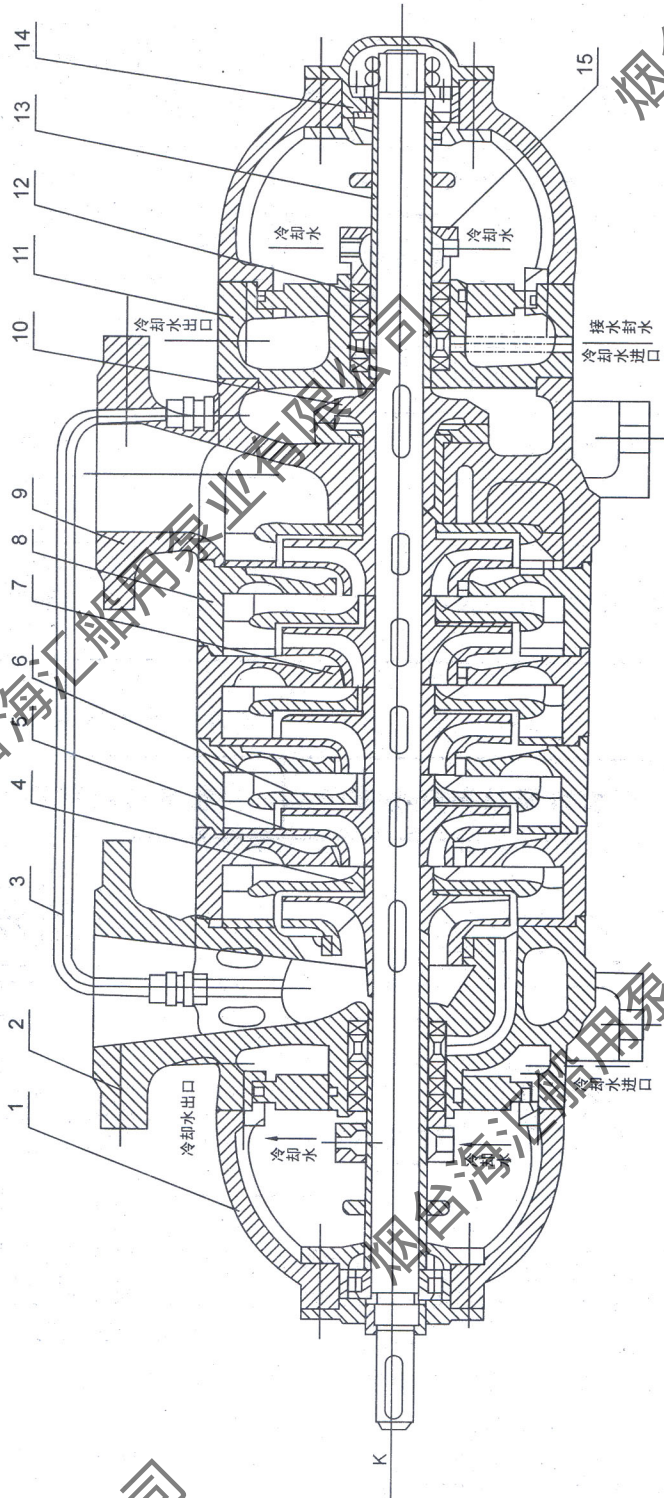

- 1、轴承体    2、吸入段    3、平衡管    4、导叶套    5、叶轮    6、导叶    7、密封环
- 8、中段    9、吐出段    10、平衡盘    11、尾盖    12、填料    13、O型密封圈    14、轴承部件
- 15、水冷填料压盖



表1

泵型号	轴 承			润滑方式	冷却方式
	名 称	型 号	每 台 泵 用 数 量		
D.DG25-50	单列向心短圆柱滚轴承	2308	2付	脂润滑	
D.DG46-50	"	2308	2付	"	
D.40DG-40	"	2306	2付	"	
D.DG80-30	"	2307	2付	"	
D.DG85-67	滑动轴承	巴氏合金	2付	稀油	水冷
D.DG155-67		"	2付	"	"
D.DG6-25 12-25	单列向心短圆柱滚子轴承	2306	2付	脂润滑	"

表2

泵型号	吸入侧填料及填料环分布	吐出侧填料及填料环分布
D.DG25-50 D.DG46-50		
D.40DG-40		
D.DG80-30		
D.DG85-67 D.DG155-67		

### 三、泵的装配与拆卸

#### 1. 泵的装配

本型泵装配质量的好坏直接影响泵能否正常工作，影响泵的使用寿命和性能，影响机组振动和噪音。装配中应注意以下几点。

a. 固定部分各零件组装后的同心度靠零件制造精度和装配质量来保证，应保护好零件的加工精度和表面粗糙度，不允许碰、划伤，作密封剂用的二硫化钼应干净，紧固用的螺钉、螺栓应受力均匀。

b. 叶轮出口流道与导叶进口流量的对中性是依各零件轴向尺寸保证，流道的对中性的好坏，直接影响泵性能，故泵的尺寸不能随意调整。

c. 泵装配完毕，在未装填料前，用手转动泵转子，检查转子在泵壳体中旋转是否灵活，轴向窜动量是否达到规定要求。

d. 上述检查合格后，在泵两端填料室内压入填料，注意填料环在填料室中的相对位置。

#### 2. 泵均拆卸

a. 泵的拆卸按装配相反的顺序进行，拆卸时应严格保护泵上各零件制造精度不受损伤。

b. 拆卸穿杆的同时应将各中段用垫垫起，以免各中段止口的松动下沉将轴压弯。

### 四、泵的安装

除了一般的安装要求外，安装本型泵，应注意以下两点：

1. 电机与泵联轴器之间应保持一定间隙，此间隙值应接近泵轴的串动量，一般为3~5mm。

2. 电机与泵的轴心线必须在同一平面内成为直线，可用塞尺测量两联轴器端面间隙的均匀度，在园周各个方向上最大和最小间隙差不得超过0.2毫米，两端面中心线上下或左右的差数不得超过0.1毫米。

### 五、泵的起动、运行、停车

起动：1. 泵起动前应盘动转子，检查转子是否灵活。

2. 检查电机转向是否与泵转向一致。

3. 关闭出口闸阀。压力表旋塞，用输送的液体或真空系统排除吸入管和泵内的空气。

4. 检查泵与电机联接螺栓的松紧程度和泵周围的安全情况，使泵处于准备起动状态。

5. 起动泵，待泵运转正常后，打开压力表旋塞，慢慢开启泵出口闸阀，按出口压力表读数控制泵给定的扬程。

运行：1. 本型泵靠泵内平衡结构平衡轴向力，平衡装置内有平衡液体流出。平衡液由平衡水管接至吸入段。为保证泵正常工作，平衡水管绝对不允许堵塞。

2. 本型泵滚动轴承均无冷却装置，轴承温升变化反映了泵的装配质量。轴承温升不得高于环境温度35℃，轴承的最高不得高于75℃。

3. 本型泵转子在运行中存在一定的轴向游动，应保证电机和泵两联轴器端面间的间隙值。

4. 泵在运行期间应定期检查叶轮，密封环，导叶套，轴套，平衡盘的磨损情况，磨损过大时应予以及时更换。

5. 泵在使用中根据具体情况，订出详细操作规程。

停车：停车前应先关闭压力表旋塞，慢慢关闭出口闸阀，待出口闸阀关闭完毕后再停电机。



## 六、泵可能发生的故障及解决方法

故障	原因	解决方法
1.水泵不出水	(1) 转向不对 (2) 起动前注入泵内的水不够 (当使用真空泵时, 则抽真空不够。) (3) 底阀未打开或补堵塞。 (4) 泵距水泵太高, 超过了铭牌规定值。 (5) 进水管路漏气。 (6) 仪表联接处漏气。 (7) 填料函部位漏气。 (8) 叶轮流道被堵塞。 (9) 泵转速不够。	(1) 更换电机接线 (2) 注入至少淹没叶轮, 最好充满泵腔 (抽真空时也同) (3) 检查底阀, 清洁检修, 甚至更新。 (4) 降低泵的安装高度。 (5) 检查进水管法兰面, 拧紧联接螺栓。 (6) 检查仪表接头, 封口。 (7) 检查轴套, 螺套螺母, 漏气时, 端面应加垫。 (8) 清洗叶轮。 (9) 检查电机, 找出转速不够的原因, 检查或更新, 使同水泵匹配。
2.水量不足	(1) 水流通道被堵塞。 (2) 叶轮和密封环之间的间隙漏损太大。 (3) 转速未达到规定值。	(1) 从进水口(包括水工建筑至出口依次检查流道是否畅通, 排除堵塞物。) (2) 检查或更新叶轮和密封环使间隙达到规定值。 (3) 检查电压是否过低, 检查电机是否损坏, 检修电机和调整电压, 使其转速达到规定值。
3.水泵消耗功率过大, 电机电流超过额定值。	(1) 填料压得过紧。 (2) 泵的转子与定子磨擦。 (3) 水量超过了使用范围。 (4) 平衡盘与平衡环磨擦。	(1) 调整填料。 (2) 检查转子与定子磨擦部位特别是间隙小的叶轮与密封环处。 (3) 在规定的流量范围内使用水泵。 (4) 检查平衡盘的端面跳动使之不超过规定值, 磨擦太大应更新。
4.水泵响声异常和振动	(1) 发生汽蚀。 (2) 机件松动或脱落。 (3) 转子不平衡。 (4) 轴弯曲。 (5) 泵轴与电机轴不同心。 (6) 基础薄弱。	(1) 降低水泵安装高度, 简化进水管路, 减少管路损失。 (2) 停车检查, 紧固零件。 (3) 转子作平衡试验, 车削不平衡重量。 (4) 检查主轴。 (5) 调整机组, 使之同心。 (6) 加固基础。
5.轴承过热	(1) 润滑不良。 (2) 轴弯曲。 (3) 轴承损坏。 (4) 泵轴与电机不同心。	(1) 加油 (检查油环, 使之旋转)。 (2) 调直主轴。 (3) 更换轴承。 (4) 调整机组, 使之同心。



### 七、D<sub>DG</sub> 6-25多级离心水泵性能表

型号	转速 n (r/min)	流量 Q		扬程 H (m)	效率 η (%)	功率 kw		必需汽蚀余量 MPSH) r (m)	叶轮 直径 (mm)	质量 (kg)
		m <sup>3</sup> /h	L/S			轴功率 Pa	电机 功率			
D <sub>DG</sub> 6-25×3	2950	3.75	1.04	76.5	33	2.37		2.0		
		6.3	1.75	75	45	2.36	5.5	2.0		
		7.5	2.08	73.5	47	3.19		2.5		
D <sub>DG</sub> 6-25×4	2950	3.75	1.04	102	33	3.16		2.0		
		6.3	1.75	100	45	3.81	7.5	2.0		
		7.5	2.08	98	47	4.26		2.5		
D <sub>DG</sub> 6-25×5	2950	3.75	1.04	127.5	33	3.95		2.0		
		6.3	1.75	125	45	4.77	7.5	2.0		
		7.5	2.08	122.5	47	5.32		2.5		
D <sub>DG</sub> 6-25×6	2950	3.75	1.04	153	33	4.37		2.0		
		6.3	1.75	150	45	5.72	11	2.0		
		7.5	2.08	147	47	6.39		2.5		
D <sub>DG</sub> 6-25×7	2950	3.75	1.04	178.5	33	5.52		2.0		
		6.3	1.75	175	45	6.67	11	2.0		
		7.5	2.08	171.5	47	7.45		2.5		
D <sub>DG</sub> 6-25×8	2950	3.75	1.04	204	33	6.31		2.0		
		6.3	1.75	200	45	7.63	15	2.0		
		7.5	2.08	196	47	8.52		2.5		
D <sub>DG</sub> 6-25×9	2950	3.75	1.04	229.5	33	7.10		2.0		
		6.3	1.75	225	45	8.58	15	2.0		
		7.5	2.08	220.5	47	9.58		2.5		
D <sub>DG</sub> 6-25×10	2950	3.75	1.04	255	33	7.89		2.0		
		6.3	1.75	250	45	9.53	18.5	2.0		
		7.5	2.08	245	47	10.65		2.5		
D <sub>DG</sub> 6-25×11	2950	3.75	1.04	280.5	33	8.68		2.0		
		6.3	1.75	275	45	10.5	18.5	2.0		
		7.5	2.08	269.5	47	11.71		2.5		
D <sub>DG</sub> 6-25×12	2950	3.75	1.04	306	33	9.47		2.0		
		6.3	1.75	300	45	11.44	18.5	2.0		
		7.5	2.08	294	47	12.78		2.5		



D<sub>DG</sub> 12-25多级离心水泵性能表

型 号	转速 n (r/min)	流量 Q		扬程 H (m)	效率 η (%)	功 率 kw		必需汽蚀余量 (MPSH) r (m)	叶轮 直径 (mm)	质量 (kg)
		m <sup>3</sup> /h	L/S			轴功率 Pa	电机 功率			
D <sub>DG</sub> 12-25×3	2950	7.5	2.08	84.6	44	3.93	7.5	2.0		
		12.5	3.47	75	54	4.73		2.0		
		15.0	4.17	69	53	5.32		2.5		
D <sub>DG</sub> 12-25×4	2950	7.5	2.08	112.8	44	5.24	11	2.0		
		12.5	3.47	100	54	6.30		2.0		
		15.0	4.17	92	53	7.09		2.5		
D <sub>DG</sub> 12-25×5	2950	7.5	2.08	141	44	6.55	11	2.0		
		12.5	3.47	125	54	7.88		2.0		
		15.0	4.17	115	53	8.86		2.5		
D <sub>DG</sub> 12-25×6	2950	7.5	2.08	169.2	44	7.85	15	2.0		
		12.5	3.47	150	54	9.46		2.0		
		15.0	4.17	138	53	10.64		2.5		
D <sub>DG</sub> 12-25×7	2950	7.5	2.08	197.4	44	9.16	15	2.0		
		12.5	3.47	175	54	11.0		2.0		
		15.0	4.17	161	53	12.41		2.5		
D <sub>DG</sub> 12-25×8	2950	7.5	2.08	225.6	44	10.47	18.5	2.0		
		12.5	3.47	200	54	12.61		2.0		
		15.0	4.17	184	53	14.18		2.5		
D <sub>DG</sub> 12-25×9	2950	7.5	2.08	253.8	44	11.78	18.5	2.0		
		12.5	3.47	225	54	14.18		2.0		
		15.0	4.17	207	53	15.95		2.5		
D <sub>DG</sub> 12-25×10	2950	7.5	2.08	282	44	13.09	22	2.0		
		12.5	3.47	250	54	15.76		2.0		
		15.0	4.17	230	53	17.73		2.5		
D <sub>DG</sub> 12-25×11	2950	7.5	2.08	310.2	44	14.4	22	2.0		
		12.5	3.47	275	54	17.34		2.0		
		15.0	4.17	253	53	19.5		2.5		
D <sub>DG</sub> 12-25×12	2950	7.5	2.08	338.4	44	15.7	30	2.0		
		12.5	3.47	300	54	18.9		2.0		
		15.0	4.17	276	53	21.3		2.5		

D<sub>DG</sub> 25-30多级离心水泵性能表

型 号	转速 n (r/min)	流量 Q		扬 程 H (m)	效率 η (%)	功 率 kw		必需汽蚀余量 (MPSH) r (m)	叶轮 直径 (mm)	质量 (kg)
		m <sup>3</sup> /h	L/S			轴功率 Pa	电机 功率			
D <sub>DG</sub> 25-30×3	2950	15	4.17	102	50	8.33	15	2.2		
		25	6.94	90	62	9.88				
		30	8.33	82.5	63	10.7				
D <sub>DG</sub> 25-30×4	2950	15	4.17	136	50	11.11	18.5	2.2		
		25	6.94	120	62	13.1				
		30	8.33	110	63	14.26				
D <sub>DG</sub> 25-30×5	2950	15	4.17	170	50	13.89	22	2.2		
		25	6.94	150	62	16.47				
		30	8.33	137.5	63	17.83				
D <sub>DG</sub> 25-30×6	2950	15	4.17	204	50	16.67	30	2.2		
		25	6.94	180	62	19.77				
		30	8.33	165	63	21.4				
D <sub>DG</sub> 25-30×7	2950	15	4.17	238	50	19.44	30	2.2		
		25	6.94	210	62	23.1				
		30	8.33	192.5	63	24.96				
D <sub>DG</sub> 25-30×8	2950	15	4.17	272	50	22.22	37	2.2		
		25	6.94	240	62	26.4				
		30	8.33	220	63	28.53				
D <sub>DG</sub> 25-30×9	2950	15	4.17	306	50	25.0	37	2.2		
		25	6.94	270	62	29.65				
		30	8.33	247.5	63	32.1				
D <sub>DG</sub> 25-30×10	2950	15	4.17	340	50	27.8	45	2.2		
		25	6.94	300	62	32.9				
		30	8.33	275	63	35.7				



D  
DG 25-50多级离心水泵性能表

型 号	转速 n (r/min)	流量 Q		扬 程 H (m)	轴功率 Pa ( kw )	电机 功率 ( kw )	效 率 ( % )	必需汽蚀余量 ( MPSH ) r ( m )	叶轮 直径 D <sub>2</sub> (mm)
		m <sup>3</sup> /h	L/S						
D DG 25-50×3	2950	15	4.16	154.5	14.3	30	44	2.4	
		25	6.94	150	18.9		54	2.7	
		28	7.78	144	20.3		54	2.8	
D DG 25-50×4	2950	15	4.16	206	19.1	30	44	2.4	
		25	6.94	200	25.2		54	2.7	
		28	7.78	192	27.1		54	2.8	
D DG 25-50×5	2950	15	4.16	257.5	23.9	37	44	2.4	
		25	6.94	250	31.5		54	2.7	
		28	7.78	240	33.9		54	2.8	
D DG 25-50×6	2950	15	4.16	309	28.6	45	44	2.4	
		25	6.94	300	37.8		54	2.7	
		28	7.78	288	40.7		54	2.8	
D DG 25-50×7	2950	15	4.16	360.5	33.4	55	44	2.4	
		25	6.94	350	44.1		54	2.7	
		28	7.78	336	47.5		54	2.8	
D DG 25-50×8	2950	15	4.16	412	38.2	75	44	2.4	
		25	6.94	400	50.4		54	2.7	
		28	7.78	384	54.2		54	2.8	
D DG 25-50×9	2950	15	4.16	463.5	43.0	75	44	2.4	
		25	6.94	450	56.7		54	2.7	
		28	7.78	432	61.0		54	2.8	
D DG 25-50×10	2950	15	4.16	515	47.7	75	44	2.4	
		25	6.94	500	63.0		54	2.7	
		28	7.78	480	67.8		54	2.8	
D DG 25-50×11	2950	15	4.16	566	52.5	90	44	2.4	
		25	6.94	550	69.3		54	2.7	
		28	7.78	528	74.6		54	2.8	
D DG 25-50×12	2950	15	4.16	618	57.3	100	44	2.4	
		25	6.94	600	75.6		54	2.7	
		28	7.78	576	81.4		54	2.8	

D  
DG 46-30多级离心水泵性能表

型 号	转速 n (r/min)	流量 Q		扬程 H (m)	效率 $\eta$ (%)	功 率 kw		必需汽蚀余量 (MPSH) r (m)	叶轮 直径 (mm)	质量 (kg)
		m <sup>3</sup> /h	L/S			轴功率 Pa	电机 功率			
D DG 46-30×3	2950	30	8.33	102	64	13.02	22	2.4		
		46	12.8	90	70	16.11		3.0		
		55	15.3	81	68	17.84		4.6		
D DG 46-30×4	2950	30	8.33	136	64	17.36	30	2.4		
		46	12.8	120	70	21.48		3.0		
		55	15.3	108	68	23.79		4.6		
D DG 46-30×5	2950	30	8.33	170	64	21.7	37	2.4		
		46	12.8	150	70	26.85		3.0		
		55	15.3	135	68	29.74		4.6		
D DG 46-30×6	2950	30	8.33	204	64	26.04	37	2.4		
		46	12.8	180	70	32.21		3.0		
		55	15.3	162	68	35.68		4.6		
D DG 46-30×7	2950	30	8.33	238	64	30.38	45	2.4		
		46	12.8	210	70	37.58		3.0		
		55	15.3	189	68	41.63		4.6		
D DG 46-30×8	2950	30	8.33	274	64	34.72	55	2.4		
		46	12.8	240	70	42.95		3.0		
		55	15.3	216	68	47.58		4.6		
D DG 46-30×9	2950	30	8.33	306	64	39.06	55	2.4		
		46	12.8	270	70	48.32		3.0		
		55	15.3	243	68	53.53		4.6		
D DG 46-30×10	2950	30	8.33	340	64	43.4	75	2.4		
		46	12.8	300	70	53.69		3.0		
		55	15.3	270	68	59.47		4.6		



D  
DG 46-50多级离心水泵性能表

型 号	转速 n (r/min)	流量 Q		扬程 H (m)	效率 $\eta$ (%)	功 率 kw		必需汽蚀余量 (NPSH) r (m)	叶轮 直径 (mm)	质量 (kg)
		m <sup>3</sup> /h	L/S			轴功率 Pa	电机 功率			
D DG 46-50×3	2950	30	8.33	166.5	54	25.19	37	2.5		
		46	12.8	150	63	29.83		2.8		
		55	15.3	138	64	32.3		3.2		
D DG 46-50×4	2950	30	8.33	222	54	33.59	45	2.5		
		46	12.8	200	63	39.77		2.8		
		55	15.3	184	64	43.06		3.2		
D DG 46-50×5	2950	30	8.33	277.5	54	41.98	55	2.5		
		46	12.8	250	63	49.71		2.8		
		55	15.3	230	64	53.83		3.2		
D DG 46-50×6	2950	30	8.33	333	54	50.38	75	2.5		
		46	12.8	300	63	59.69		2.8		
		55	15.3	276	64	64.59		3.2		
D DG 46-50×7	2950	30	8.33	388.5	54	58.78	75	2.5		
		46	12.8	350	63	69.6		2.8		
		55	15.3	322	64	75.36		3.2		
D DG 46-50×8	2950	30	8.33	440	54	67.18	90	2.5		
		46	12.8	400	63	79.54		2.8		
		55	15.3	368	64	86.12		3.2		
D DG 46-50×9	2950	30	8.33	499.5	54	75.57	110	2.5		
		46	12.8	450	63	89.48		2.8		
		55	15.3	414	64	96.89		3.2		
D DG 46-50×10	2950	30	8.33	555	54	83.97	110	2.5		
		46	12.8	500	63	99.42		2.8		
		55	15.3	460	64	107.66		3.2		
D DG 46-50×11	2950	30	8.33	610.5	54	92.37	132	2.5		
		46	12.8	550	63	109.36		2.8		
		55	15.3	506	64	118.42		3.2		
D DG 46-50×12	2950	30	8.33	666	54	100.8	132	2.5		
		46	12.8	600	63	119.3		2.8		
		55	15.3	552	64	129.2		3.2		

D<sub>DG</sub> 85-45多级离心水泵性能表

型 号	转速 n (r/min)	流量 Q		扬程 H (m)	效率 η (%)	功率 kw		必需汽蚀余量 (MPSH) r (m)	叶轮 直径 (mm)	质量 (kg)
		m <sup>3</sup> /h	L/S			轴功率 Pa	电机 功率			
D <sub>DG</sub> 85-45×2	2950	55	15.3	102	63	24.25	37	3.2		
		85	23.6	90	72	28.94		4.2		
		100	27.8	78	70	30.35		5.2		
D <sub>DG</sub> 85-45×3	2950	55	15.3	153	63	36.38	55	3.2		
		85	23.6	135	72	43.4		4.2		
		100	27.8	117	70	45.52		5.2		
D <sub>DG</sub> 85-45×4	2950	55	15.3	204	63	48.5	75	3.2		
		85	23.6	180	72	57.87		4.2		
		100	27.8	156	70	60.7		5.2		
D <sub>DG</sub> 85-45×5	2950	55	15.3	255	63	60.63	90	3.2		
		85	23.6	225	72	72.34		4.2		
		100	27.8	195	70	75.86		5.2		
D <sub>DG</sub> 85-45×6	2950	55	15.3	306	63	72.75	110	3.2		
		85	23.6	270	72	86.81		4.2		
		100	27.8	234	70	91.04		5.2		
D <sub>DG</sub> 85-45×7	2950	55	15.3	357	63	84.88	132	3.2		
		85	23.6	315	72	101.3		4.2		
		100	27.8	273	70	106.2		5.2		
D <sub>DG</sub> 85-45×8	2950	55	15.3	408	63	97.0	132	3.2		
		85	23.6	360	72	115.7		4.2		
		100	27.8	312	70	121.4		5.2		
D <sub>DG</sub> 85-45×9	2950	55	15.3	459	63	109.1	160	3.2		
		85	23.6	405	72	130.2		4.2		
		100	27.8	351	70	136.6		5.2		



D<sub>85-67</sub>型泵工作性能表

级数	流量 Q		扬程 H (m)	转速 n (r/min)	轴功率 Pa (kw)	电机功率 (kw)	效率 η (%)	必需汽蚀余量 (MPSH) r (m)	叶轮直径 D <sub>2</sub> (mm)
	m <sup>3</sup> /h	L/S							
3	55	15.28	222	2950	57.3	90	58	3.3	
	85	23.61	201		68.4		68	4.0	
	100	27.78	183		73.3		68	4.4	
4	55	15.28	296		76.4	110	58	3.3	
	85	23.61	268		91.2		68	4.0	
	100	27.78	244		97.7		68	4.4	
5	55	15.28	370		95.6	132	58	3.3	
	85	23.61	335		114.4		68	4.0	
	100	27.78	305		122.2		68	4.4	
6	55	15.28	444	114.7	160	58	3.3		
	85	23.61	402	136.9		68	4.0		
	100	27.78	365	146.6		68	4.4		
7	55	15.28	518	133.8	180	58	3.3		
	85	23.61	469	159.6		68	4.0		
	100	27.78	427	171		68	4.4		
8	55	15.28	592	152.9	220	58	3.3		
	85	23.61	536	182.4		68	4.0		
	100	27.78	488	195.4		68	4.4		
9	55	15.28	666	172	250	58	3.3		
	85	23.61	603	205.2		68	4.0		
	100	27.78	549	219.9		68	4.4		

D<sub>85-67</sub>型泵外形安装尺寸表

(单位: 毫米)

泵型号	级数	外形安装尺寸(公用底座)																	电动机																
		L	L <sub>1</sub>	L <sub>2</sub>	L <sub>3</sub>	L <sub>4</sub>	L <sub>5</sub>	L <sub>6</sub>	L <sub>7</sub>	L <sub>8</sub>	C	B	B <sub>1</sub>	B <sub>2</sub>	H	H <sub>1</sub>	H <sub>2</sub>	h	h <sub>1</sub>	n~φd	型号	功率 kw													
DG85-67	3	2465	1895	600	1200	320	479	317	559	280	4	330	670	670	430	350	360	50	6~φ25		Y280M-2	90													
	4	2691	2020	710	1420	330		459													220	Y315S-2	110												
	5	2829	2250	750	1500	375		547													235	630	750	470	45	60	Y315M <sub>1</sub> -2	132							
	6	2917						635													280	640	880	505	495	50	JS <sub>2</sub> 355M <sub>2</sub> -2	190							
	7	3005	2450	800	1600	460		723													360	650	970	560	560	60	JS <sub>2</sub> 400S <sub>1</sub> -2	220							
	8	3273	2655	855	1710	555		811													406	650	970	560	560	60									
	9	3361	2665	855	1710	555		899													450														

D  
DG 155-30多级离心水泵性能表

型 号	转速 n (r/min)	流量 Q		扬程 H (m)	效率 $\eta$ (%)	功 率 kw		必需汽蚀余量 (MPSH) r (m)	叶轮 直径 (mm)	质量 (kg)
		m <sup>3</sup> /h	L/S			轴功率 Pa	电机 功率			
150D-30X2	1480	100	27.8	65	64	27.66	55	3.2		
		155	43	60	75	33.77		3.9		
		185	51.4	55	75	36.95		4.8		
D DG 155-30×3	1480	100	27.8	97.5	64	41.2	75	3.2		
		155	43	90	75	50.65		3.9		
		185	51.4	82.5	75	55.42		4.8		
D DG 155-30×4	1480	100	27.8	130	64	55.32	90	3.2		
		155	43	120	75	67.54		3.9		
		185	51.4	110	75	73.9		4.8		
D DG 155-30×5	1480	100	27.8	162.5	64	69.15	110	3.2		
		155	43	150	75	84.42		3.9		
		185	51.4	137.5	75	92.37		4.8		
D DG 155-30×6	1480	100	27.8	195	64	82.98	132	3.2		
		155	43	180	75	101.3		3.9		
		185	51.4	165	75	110.8		4.8		
D DG 155-30×7	1480	100	27.8	227.5	64	96.81	160	3.2		
		155	43	210	75	118.2		3.9		
		185	51.4	192.5	75	129.3		4.8		
D DG 155-30×8	1480	100	27.8	260	64	110.6	180	3.2		
		155	43	240	75	135.1		3.9		
		185	51.4	220	75	147.8		4.8		
D DG 155-30×9	1480	100	27.8	292.5	64	124.5	180	3.2		
		155	43	270	75	125		3.9		
		185	51.4	247.5	75	166.3		4.8		
D DG 155-30×10	1480	100	27.8	325	64	138.3	220	3.2		
		155	43	300	75	168.8		3.9		
		185	51.4	275	75	184.7		4.8		



D<sub>DG</sub>155-67多级离心水泵性能表

型 号	转速 n (r/min)	流量 Q		扬程 H (m)	效率 η (%)	功 率 kw		必需汽蚀余量 (MPSH) r (m)	叶轮 直径 (mm)	质量 (kg)
		m <sup>3</sup> /h	L/S			轴功率 Pa	电机 功率			
D <sub>DG</sub> 155-67×3	2950	100	27.8	228	64	97.0	132	3.2		
		155	43	201	74	114.7		5.0		
		185	51.4	177	72	123.9		6.6		
D <sub>DG</sub> 155-67×4	2950	100	27.8	304	64	129.4	185	3.2		
		155	43	268	74	152.9		5.0		
		185	51.4	236	72	165.1		6.6		
D <sub>DG</sub> 155-67×5	2950	100	27.8	380	64	161.7	220	3.2		
		155	43	335	74	191.1		5.0		
		185	51.4	295	72	206.4		6.6		
D <sub>DG</sub> 155-67×6	2950	100	27.8	456	64	194	280	3.2		
		155	43	402	74	229.3		5.0		
		185	51.4	354	72	247.7		6.6		
D <sub>DG</sub> 155-67×7	2950	100	27.8	532	64	226.4	350	3.2		
		155	43	496	74	267.5		5.0		
		185	51.4	413	72	289		6.6		
D <sub>DG</sub> 155-67×8	2950	100	27.8	608	64	258.7	350	3.2		
		155	43	536	74	305.7		5.0		
		185	51.4	472	72	330.3		6.6		
D <sub>DG</sub> 155-67×9	2950	100	27.8	684	64	291.1	440	3.2		
		155	43	603	74	344		5.0		
		185	51.4	521	72	371.6		6.6		

D<sub>DG</sub>280-43多级离心水泵性能表

型 号	转速 n (r/min)	流量 Q		扬程 H (m)	效率 η (%)	功 率 kw		必需汽蚀余量 (NPSH) r ( m )	叶轮 直径 ( mm )	质量 ( kg )
		m <sup>3</sup> /h	L/S			轴功率 Pa	电机 功率			
D <sub>DG</sub> 280-43×2	1480	185	51.4	94	69	68.6	110	3.0		
		280	77.8	86	77	85.17		4.7		
		335	93.1	76	75	92.4		6.0		
D <sub>DG</sub> 280-43×3	1480	185	51.4	141	69	103	160	3.0		
		280	77.8	129	77	127.7		4.7		
		335	93.1	114	75	138.7		6.0		
D <sub>DG</sub> 280-43×4	1480	185	51.4	188	69	137.3	250	3.0		
		280	77.8	172	77	170.3		4.7		
		335	93.1	152	75	184.9		6.0		
D <sub>DG</sub> 280-43×5	1480	185	51.4	235	69	171.6	250	3.0		
		280	77.8	215	77	212.9		4.7		
		335	93.1	190	75	231.1		6.0		
D <sub>DG</sub> 280-43×6	1480	185	51.4	282	69	205.9	315	3.0		
		280	77.8	258	77	255.5		4.7		
		335	93.1	228	75	277.3		6.0		
D <sub>DG</sub> 280-43×7	1480	185	51.4	329	69	240.2	350	3.0		
		280	77.8	301	77	298.1		4.7		
		335	93.1	266	75	323.6		6.0		
D <sub>DG</sub> 280-43×8	1480	185	51.4	376	69	274.5	400	3.0		
		280	77.8	344	77	304.7		4.7		
		335	93.1	304	75	369.8		6.0		
D <sub>DG</sub> 280-43×9	1480	185	51.4	423	69	308.9	450	3.0		
		280	77.8	387	77	383.2		4.7		
		335	93.1	342	75	416		6.0		



D<sub>DG</sub> 280-65多级离心水泵性能表

型号	转速 n (r/min)	流量 Q		扬程 H (m)	效率 η (%)	功率 kw		必需汽蚀余量 (MPa) r (m)	叶轮 直径 (mm)	质量 (kg)
		m <sup>3</sup> /h	L/S			轴功率 Pa	电机 功率			
D <sub>DG</sub> 280-65×6	1480	185	51.4	408	61	337	500	2.8		
		280	77.8	390	73	407.4		3.7		
		335	93.1	372	75	452.5		5.0		
D <sub>DG</sub> 280-65×7	1480	185	51.4	476	61	393.1	680	2.8		
		280	77.8	455	73	475.3		3.7		
		335	93.1	434	75	528		5.0		
D <sub>DG</sub> 280-65×8	1480	185	51.4	544	61	449.3	680	2.8		
		280	77.8	520	73	543.2		3.7		
		335	93.1	496	75	603.3		5.0		
D <sub>DG</sub> 280-65×9	1480	185	51.4	612	61	505.5	850	2.8		
		280	77.8	585	73	611.2		3.7		
		335	93.1	558	75	678.8		5.0		
D <sub>DG</sub> 280-65×10	1480	185	51.4	680	61	561.6	850	2.8		
		280	77.8	650	73	679		3.7		
		335	93.1	620	75	754.2		5.0		

D<sub>DG</sub> 450-60多级离心水泵性能表

型 号	转速 n (r/min)	流量 Q		扬程 H (m)	效率 η (%)	功 率 kw		必需汽蚀余量 (MRS <sub>H</sub> ) r (m)	叶轮 直径 (mm)	质量 (kg)
		m <sup>3</sup> /h	L/S			轴功率 P <sub>a</sub>	电机 功率			
D <sub>DG</sub> 450-60×3	1480	335	93.1	195	72	247.1	360	3.8		
		450	125	180	79	279.2		4.9		
		500	139	171	78	298.5		6.0		
D <sub>DG</sub> 450-60×4	1480	335	93.1	260	72	329.4	500	3.8		
		450	125	240	79	372.3		4.9		
		500	139	228	78	398		6.0		
D <sub>DG</sub> 450-60×5	1480	335	93.1	325	72	411.8	680	3.8		
		450	125	300	79	465.4		4.9		
		500	139	285	78	497.2		6.0		
D <sub>DG</sub> 450-60×6	1480	335	93.1	390	72	494.2	680	3.8		
		450	125	360	79	558.5		4.9		
		500	139	342	78	597		6.0		
D <sub>DG</sub> 450-60×7	1480	335	93.1	445	72	576.5	850	3.8		
		450	125	420	79	651.5		4.9		
		500	139	399	78	696.5		6.0		
D <sub>DG</sub> 450-60×8	1480	335	93.1	520	72	658.9	850	3.8		
		450	125	480	79	744.6		4.9		
		500	139	456	78	796		6.0		
D <sub>DG</sub> 450-60×9	1480	335	93.1	585	72	741.2	1050	3.8		
		450	125	540	79	837.7		4.9		
		500	139	513	78	895.6		6.0		
D <sub>DG</sub> 450-60×10	1480	335	93.1	650	72	823.6	1050	3.8		
		450	125	600	79	930.8		4.9		
		500	139	570	78	995.1		6.0		



### 八、泵外形安装尺寸



图3 D、DG型多级离心水泵安装图（共同底座）



图4 D、DG型多级离心水泵安装图（单独底座）

### D、DG型泵外形安装尺寸表

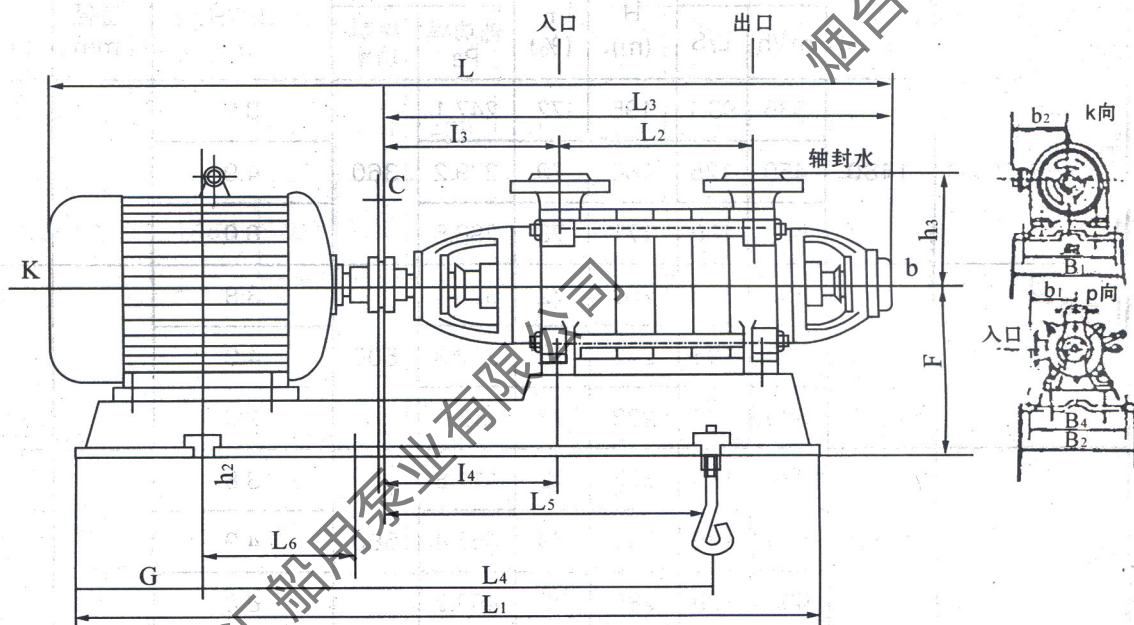
产品型号	电机		外型安装尺寸表																																			
	型号q	功率	底座	L	L <sub>1</sub>	L <sub>2</sub>	L <sub>3</sub>	L <sub>4</sub>	L <sub>5</sub>	L <sub>6</sub>	l <sub>1</sub>	l <sub>2</sub>	l <sub>3</sub>	l <sub>4</sub>	A	B <sub>1</sub>	B <sub>2</sub>	B <sub>3</sub>	B <sub>4</sub>	b <sub>1</sub>	b <sub>2</sub>	C	H	H <sub>1</sub>	h	h <sub>1</sub>	h <sub>2</sub>	h <sub>3</sub>	e	K	G	F	n-φd	GB199-6 Md x L				
D.DG6-25 x 3	Y132S1-2	5.5	共	1175	985	180	695	600	358												170											140	220					
D.DG6-25 x 4	Y132S2-2	7.5	同	1225	985	230	745	600	408												170																	
D.DG6-25 x 5	Y132D2-2			1275	280	795																																
D.DG6-25 x 6	Y160M1-2	11	底	1450	1140	330	845	725	459												170																	
D.DG6-25 x 7	Y160M1-2		同	1500	1350	380	895			0			265	265		440	440	350	350		170																	
D.DG6-25 x 8	Y160M1-2	15	底	1550	430	945	820	509																														
D.DG6-25 x 9	Y160M1-2		座	1600	480	995															170																	
D.DG6-25 x 10	Y160L-2			1695	530	1045															170																	
D.DG6-25 x 11	Y160L-2	18.5		1745	1500	580	1095	935	584												170																	
D.DG6-25 x 12	Y160L-2			1795	630	1145															170																	
D.DG12-25 x 3	Y132S2-2	7.5		1175	985	180	695	600	355																													
D.DG12-25 x 4	Y160M1-2	11		1350	1140	230	745	725	380																													
D.DG12-25 x 5	Y160M1-2			1400	1140	280	795	725	403																													
D.DG12-25 x 6	Y160M2-2	15		1450	1140	330	845	725	413																													
D.DG12-25 x 7	Y160M2-2			1500	1350	380	895	820	458																													
D.DG12-25 x 8	Y160L-2	18.5	共	1595	1350	430	945	820	479	0																												
D.DG12-25 x 9	Y160L-2		同	1645	1350	480	995	820	501																													
D.DG12-25 x 10	Y180M-2	22	底	1720	1470	530	1045	900	520																													
D.DG12-25 x 11	Y180M-2		座	1770	1470	580	1095	900	550																													
D.DG12-25 x 12	Y200L1-2	30		1925	1571	630	1145	980	578																													
D.DG25-30 x 3	Y160M2-2	15		1450	1260	230	845	850	432																													
D.DG25-30 x 4	Y160L-2	18.5		1560	1260	295	910	850	478																													
D.DG25-30 x 5	Y180M-2	22		1650	1297	360	975	880	510																													
D.DG25-30 x 6	Y200L1-2	30		1825	1432	425	1045	930	553																													

(按表尺寸如有变动, 请参照水泵实际尺寸, 恕不另行通知)

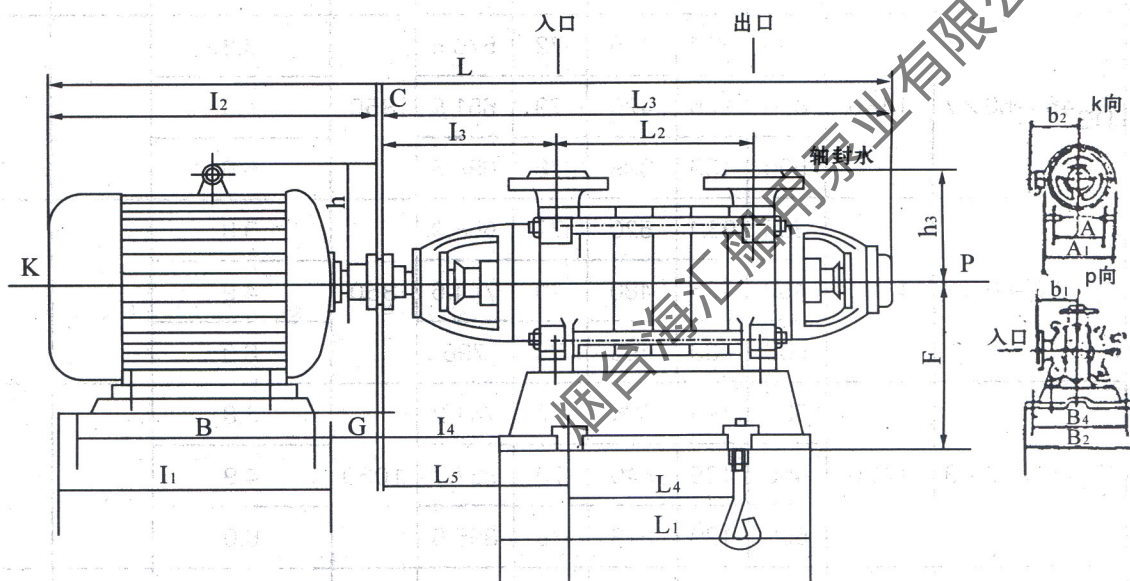

### D、DG型泵外形安装尺寸表

产品型号	电机		外形尺寸																							安装		GB199-6 M d x L									
	型号	功率	L	L1	L2	L3	L4	L5	L6	l1	l2	l3	l4	A	A1	B	B1	B2	B3	B4	b1	b2	C	H	H1	h	h1		h2	h3	e	K	G	F	n-φd		
D、DG25-30×7	Y200L-2	30	1885	1627	490	1105	1080	583	0									210	575	475	210	310														M24×400	
D、DG25-30×8	Y100L2-2	37	1950	1627	555	1170	1080	613		300	315							210	575	475	210	310															
D、DG25-30×9	Y200L2-2		2015	1627	620	1235	1080	663											210	610	540	210	345														
D、DG25-30×10	Y225M-2	45	2150	1728	685	1330	1120	677										210	530	430	210	285															
D、DG46-30×3	Y180M-2	22	1520	1260	230	845	600	487										210	530	430	210	285															
D、DG46-30×4	Y200L1-2	30	1690	1432	295	910	930	487										210	575	490	210	310															
D、DG46-30×5	Y200L2-2	37	1755	1432	360	975	930	503										210	575	490	210	310															
D、DG46-30×6	Y200L2-2	37	1820	1432	425	1040	935	528	0	330	315							210	575	530	210	310															
D、DG46-30×7	Y250M-2	45	1925	1550	490	1105	1010	580										210	615	530	210	345															
D、DG46-30×8	Y250M-2	55	2105	1694	555	1170	1130	600										210	664	560	210	385															
D、DG46-30×9	Y250M-2		2170	159	620	1235	1130	600										210	720	640	210	410															
D、DG46-30×10	Y280S-2	75	2305	1897	685	1300	1245	679										210	720	640	210	410															
D、DG46-50×3	Y200L2-2	37	1717	1475	245	937	910	4755										300	570	480	300	310															
D、DG46-50×4	Y225M-2	45	1817	1520	305	997	930	460.5	0									300	620	530	300	345															
D、DG46-50×5	Y250M-2	55	1992	1680	365	1057	1120	535.5										300	370	640	300	385															
D、DG46-50×6	Y280S-2	75	2122	1789	245	1117	1130	615	565									300	720	625	300	410															
D、DG46-50×7	Y280S-2		2182	485	1177								353	320.5				300	720	625	300	410															
D、DG46-50×8	Y280M-2	90	2292	1869	545	1237	1180	665.5	590									300	820	750	300	530															
D、DG46-50×9	Y315S-2	110	2473	2046	605	1297	1330	770.5	665									300	820	750	300	530															
D、DG46-50×10	Y315S-2		2533	665	1357													300	820	750	300	530															
D、DG46-50×11	Y315M1-2	132	2641	2222	725	1417	1480	880.5	740									300	820	750	300	530															
D、DG46-50×12	Y315M1-2		2701	785	1477													300	820	750	300	530															
D、DG85-45×2	Y200L2-2	37	1613	1263	203	882	850	425	0									580	580	500	250	310															
D、DG85-45×3	Y250M-2	55	1842	1528	277	906	1040	473										675	600	600	385	385															



### D、DG型泵外形安装尺寸表

产品型号	电机		外型安装尺寸表																																								
	型号	功率	L	L <sub>1</sub>	L <sub>2</sub>	L <sub>3</sub>	L <sub>4</sub>	L <sub>5</sub>	L <sub>6</sub>	l <sub>1</sub>	l <sub>2</sub>	l <sub>3</sub>	l <sub>4</sub>	A	B	B <sub>1</sub>	B <sub>2</sub>	B <sub>3</sub>	B <sub>4</sub>	b <sub>1</sub>	b <sub>2</sub>	C	H	H <sub>1</sub>	h	h <sub>1</sub>	h <sub>2</sub>	h <sub>3</sub>	e	K	G	F	n-Φd	GB109-6 Md×L									
D85-45×4	Y280S-2	75	1986	1740	351	980	1070	570	530																																		
D85-45×5	Y280M-2	90	2110	1740	425	1054	1070	549	560																																		
D85-45×6	Y315S-2	110	2324	683	499	1128	303			620	1192	326	309																														
D85-45×7	Y315M <sub>1</sub> -2	132	2448	575	573	1202	377																																				
D85-45×8	Y315M <sub>1</sub> -2		2522	831	647	1276	451	430	0	670	1242				508	635	457																										
D85-45×9	Y315M <sub>2</sub> -2	160	2596	905	721	1350	525																																				
D155-30×3	Y250M-4	55	2065	1550	310	1131	1060	122.5	5300																																		
D155-30×4	Y280S-4	75	2250	1730	425	1246	1200	175	550																																		
D155-30×5	Y280M-4	90	2415	1895	540	1361	1200	217	630																																		
D155-30×6	Y315S-4	110	2670	800	655	1476	450			620	1190																																
D155-30×7	Y315M <sub>1</sub> -4	132	2835	915	770	1591	565			670	1240	430	455																														
D155-30×8	Y315M <sub>2</sub> -4	160	2950	1030	885	1706	680	524																																			
D155-30×9	JR117-4	180	3595	1145	1000	1821	795			730	1770																																
D155-30×10	JR117-4		3710	1260	1115	1936	910																																				
D155-67×3	JR126-4	225	3785	1375	1230	2051	1025	524		690	1730	430	455																														
D155-67×4	Y315M <sub>1</sub> -2	132	2654		374	1407	541			670	1242			508	628	457																											
D155-67×5	JK122-2	185	2872	765	459	1493	400	585		690	1372																																
D155-67×6	JK123-2	220	3060		547	1583	629							710	860																												
D155-67×7	JK124-2	275	3148	945	935	1671	585			790	1472																																
D155-67×8	JK133-2	350	3566		723	1759	629																																				
D155-67×9	JK133-2	440	3654	1125	811	1847	581			1000	800																																
D280-43×2	JK134-2		3742		899	1935	625							790	960	860																											
D280-43×3	JR115-4	110	2916	495	373	1190	180			730	1720																																
	JR117-4	150	3096	625	503	1320	310				1770																																



D、DG型泵外形安装尺寸表

产品型号	电机		外型安装尺寸表																																								
	型号	功率	底座	L	L1	L2	L3	L4	L5	L6	l1	l2	l3	l4	A	A1	B	B1	B2	B3	B4	b1	b2	C	H	H1	h	h1	h2	h3	e	K	G	F	n-Φd	GB799-79 Md x L							
D280-43 x 4	JR127-4	230	单独底座	3280	755	633	1450	440			790	1830			870	650							660	475	450	545	70																
D280-43 x 5	JR136-4	300	单独底座	3466	885	763	1580	570	507.5		900	1880	390	448		760																											
D280-43 x 6	JR136-4	350	单独底座	3596	1015	893	1710	700							970								720	725	445	500	330	625	500	400	6	32			480	4-Φ28	M24 x 400						
D280-43 x 7	JR137-4	350	单独底座	3858	1145	1023	1872	830			1000	1980	420	480		360																											
D280-43 x 8	JR138-4	410	单独底座	3988	1275	1153	2002	960	507.5																																		
D280-43 x 9	JR146-4	430	单独底座	4238	1405	1283	2132	1090			910	2100				1120	770						800	565	560	570	100																
D280-65 x 6	JRQ1410-4	500	单独底座	3900	1080	865	2023	700			1110	1860			940	1120	970						800	565	560																		
D280-65 x 7	JRQ158-4	680	单独底座	4065	1210	995	2158	830																																			
D280-65 x 8	JRQ158-4	680	单独底座	4195	1340	1125	2283	960	712		1150	1900	627	625		1020																											
D280-65 x 9	JRQ1510-4	850	单独底座	4425	1470	1255	2418	1090																																			
D280-65 x 10	JRQ1510-4	850	单独底座	4555	1600	1385	2543	1220			1250	2000																															
D450-60 x 3	JRQ147-4	360	单独底座	3476	770	574	1702	380			1010	1767				870																											
D450-60 x 4	JRQ1410-4	500	单独底座	3729	920	727	1855	541			1110	1867			940	1120	970						800	567	560	570																	
D450-60 x 5	JRQ158-4	680	单独底座	3917	1075	880	2008	694																																			
D450-60 x 6	JRQ158-4	680	单独底座	4070	1230	1033	2161	847	689		1150	1902	691	629		1020																											
D450-60 x 7	JRQ1510-4	850	单独底座	4323	1381	1186	2314	1000																																			
D450-60 x 8	JRQ1510-4	850	单独底座	4470	1335	1339	2467	1135																																			
D450-60 x 9	JRQ1512-4	1050	单独底座	4629	1685	1492	2620	1306			1250	2002																															
D450-60 x 10	JRQ1512-4		单独底座	4782	1840	1645	2773	1459																																			

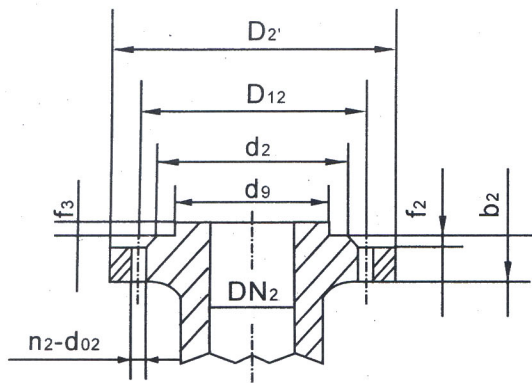

吐出口法兰

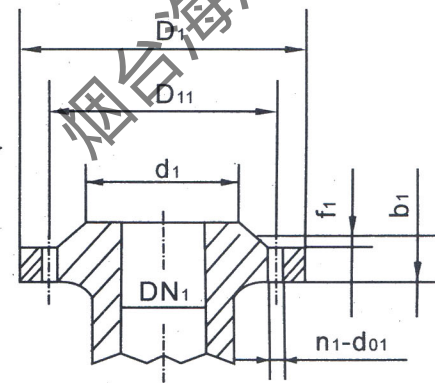

吸入口法兰

图5

表2

产品型号	吸入口法兰尺寸								排出口法兰尺寸							
	DN <sub>1</sub>	D <sub>1</sub>	D <sub>11</sub>	d <sub>1</sub>	b <sub>1</sub>	f <sub>1</sub>	n <sub>1</sub> -d <sub>01</sub>	DN <sub>2</sub>	D <sub>2</sub>	D <sub>12</sub>	d <sub>2</sub>	d <sub>3</sub>	b <sub>2</sub>	f <sub>2</sub>	f <sub>3</sub>	n <sub>2</sub> -d <sub>02</sub>
D <sub>DG</sub> 6-25	40	130	100	80	16	3	4-Φ13.5	40	150	110	88	76	18	3	4	4-Φ17.5
D <sub>DG</sub> 12-25	50	140	110	90	16	3	4-Φ13.5	40	150	110	88	76	18	3	4	4-Φ17.5
D <sub>DG</sub> 25-30	65	160	130	110	16	3	4-Φ13.5	65	185	145	122	110	20	3	4	4-Φ17.5
D <sub>DG</sub> 46-30	80	190	150	128	18	3	4-Φ17.5	65	185	145	122	110	20	3	4	4-Φ17.5
D <sub>DG</sub> 46-50	80	190	150	128	18	3	4-Φ17.5	80	210	170	140	120	30	4	4	8-Φ23
D <sub>DG</sub> 46-50	80	210	170	140	30	4	8-Φ23	80	210	170	140	120	30	4	4	8-Φ23
D <sub>DG</sub> 85-45	100	210	170	148	18	3	4-Φ17.5	100	220	180	158	150	24	3		8-Φ17.5
D <sub>DG</sub> 155-30	150	280	240	210	24	3	8-Φ23	150	300	250	218		32	3		8-Φ25
D <sub>DG</sub> 280-43	200	320	280	258	22	3	4-Φ17.5	200	340	295	268	260	30	3		12-Φ22



续 表

50DG50 型泵性能表  
D12-50

级数 STAGES	流量Q ACPACITY		扬程H Total Head m	转速 SPEED (转/分) r/min	功率POWER 千瓦(KW)		效率η EFF (%)	必需汽蚀余量 (NPSH) m	叶轮直径 IMPELLER DIAMETER mm
	m³/h	l/s			轴功率 shaft power	电机功率 motor power			
2	10	2.78	102.8	2950	6.10	11	46	2.8	192
	12.5	3.47	98.4		6.96		48		
	15	4.17	90.0		7.82		47		
3	10	2.78	154.2	2950	9.15	15	46	2.8	192
	12.5	3.47	147.6		10.4		48		
	15	4.17	135		11.7		47		
4	10	2.78	205.6	2950	12.2	22	46	2.8	192
	12.5	3.47	196.8		13.9		48		
	15	4.17	180		15.6		47		
5	10	2.78	257	2950	15.2	30	46	2.8	192
	12.5	3.47	246		17.4		48		
	15	4.17	225		19.6		47		
6	10	2.78	308.4	2950	18.3	30	46	2.8	192
	12.5	3.47	295.2		20.0		48		
	15	4.17	270		23.5		47		
7	10	2.78	359.8	2950	21.4	37	46	2.8	192
	12.5	3.47	344.4		24.5		48		
	15	4.17	315		27.6		47		
8	10	2.78	411.2	2950	24.4	37	46	2.8	192
	12.5	3.47	393.6		27.8		48		
	15	4.17	360		31.3		47		
9	10	2.78	462.6	2950	27.5	45	46	2.8	192
	12.5	3.47	442.8		31.3		48		
	15	4.17	405		35.2		47		
10	10	2.78	514	2950	30.5	55	46	2.8	192
	12.5	3.47	492		34.8		48		
	15	4.17	450		39.1		47		
11	10	2.78	565.4	2950	33.6	55	46	2.8	192
	12.5	3.47	541.2		38.3		48		
	15	4.17	495		43.0		47		
12	10	2.78	616.8	2950	36.6	55	46	2.8	192
	12.5	3.47	590.4		41.8		48		
	15	4.17	540		46.9		47		

65DG50 型泵性能表

级数 STAGES	流量Q ACPACITY		扬程H Total Head m	转速 SPEED (转/分) r/min	功率POWER 千瓦(KW)		效率η EFF (%)	必需汽蚀余量 (NPSH) m	叶轮直径 IMPELLER DIAMETER mm
	m³/h	l/s			轴功率 shaft power	电机功率 motor power			
2	15	4.17	116	2950	9.4	18.5	50.5	2.5	205
	25	6.95	104		12.4		57		
	30	8.33	95		41.1		55		
3	15	4.17	174	2950	14.1	30	50.5	2.5	205
	25	6.95	156		18.6		57		
	30	8.33	143		21.2		55		
4	15	4.17	232	2950	18.8	37	50.5	2.5	205
	25	6.95	208		24.8		57		
	30	8.33	190		28.2		55		
5	15	4.17	290	2950	23.5	45	50.5	2.5	205
	25	6.95	260		31.0		57		
	30	8.33	236		35.3		55		
6	15	4.17	348	2950	28.2	55	50.5	2.5	205
	25	6.95	312		37.2		57		
	30	8.33	285		42.4		55		
7	15	4.17	406	2950	32.9	55	50.5	2.5	205
	25	6.95	364		43.4		57		
	30	8.33	333		49.4		55		
8	15	4.17	464	2950	37.6	55	50.5	2.5	205
	25	6.95	416		49.6		57		
	30	8.33	380		56.5		55		
9	15	4.17	522	2950	42.3	75	50.5	2.5	205
	25	6.95	468		55.8		57		
	30	8.33	426		63.6		55		
10	15	4.17	580	2950	47.0	75	50.5	2.5	205
	25	6.95	520		62.0		57		
	30	8.33	475		70.6		55		
11	15	4.17	638	2950	51.7	90	50.5	2.5	205
	25	6.95	572		68.2		57		
	30	8.33	521		77.7		55		
12	15	4.17	696	2950	56.4	90	50.5	2.5	205
	25	6.95	624		74.4		57		
	30	8.33	570		84.7		55		

续 表

外形安装尺寸图 Overall and Installation Dimension

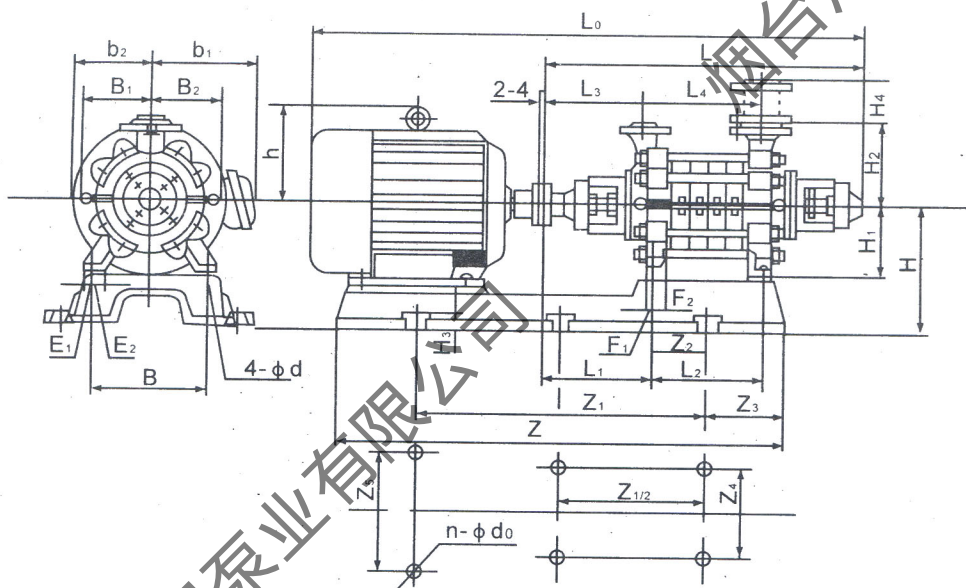

法兰尺寸表 Flange Dimension Table

型号	吸入法兰						吐出法兰						
	DN	d	k	D	b	n-z	DN	d	k	D	b	f	n-z
50DG50	50	90	110	140	16	4-14	50	87	135	175	23	4	4-23
65DG	65	110	130	160	16		65	109	160	200	28	4	8-23
80DG	80	125	150	185	18	1-17.5	80	120	170	210	30	4	8-23
100DG	100	145	170	205	18		100	149	210	265	38	4	8-30

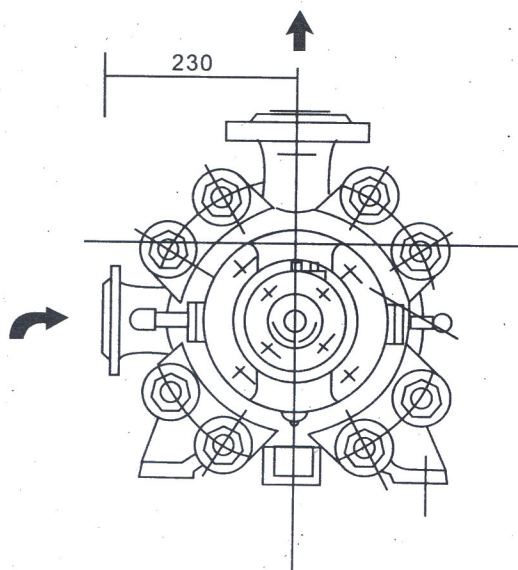

法兰图 Flange Drawing

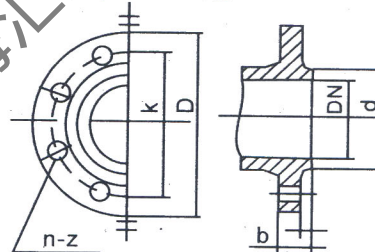

D12-50



续 表

安装尺寸表 Installation Dimension Table

型号 Type	级数 Soage	L <sub>0</sub>	H	泵 Pump																	底座 B					Y型电机 Mtor												
				L	L <sub>1</sub>	L <sub>2</sub>	L <sub>3</sub>	L <sub>4</sub>	H <sub>1</sub>	H <sub>2</sub>	B	F <sub>1</sub>	F <sub>2</sub>	E <sub>1</sub>	E <sub>2</sub>	B <sub>1</sub>	B <sub>2</sub>	d	H <sub>a</sub>	Z	Z <sub>1</sub>	Z <sub>2</sub>	Z <sub>3</sub>	Z <sub>4</sub>	Z <sub>5</sub>	H <sub>3</sub>	n-Φd0	b <sub>1</sub>	b <sub>2</sub>	h	型号/KW Madd							
50DG50 D12-50	2	1315		710		147		174											1061	734	98	157									255	165	255	160M <sub>1</sub> -2/11				
	3	1365		760		197		224											1166	788	127	1181									285	180	250	160M <sub>2</sub> -2/15				
	4	1485		810		247		274											1331	896	188			480								285	180	250	180M-2/22			
	5	1640		860		297		324											160					480										200L <sub>1</sub> -2/30				
	6	1690	300	910		347		374												1431	996	288			480	40								200L <sub>2</sub> -2/37				
	7	1740		960	310	397	278	424	200	230	320	25	40	25	40	210	16			1517	1054	327	231		540									225M-2/45				
	8	1970		1010		447		474												1713	1200	405			600										250M-2/55			
	9	1880		1060		497		524												1763	1250	455																
	10	2045	325	1110		547		574												1873	1280	434			650													
	11	2095		1160		597		624												1941	1348	492																
	12	2145	350	1210		647		674												2128	1484	603	322															
	65DG50	2	1482		833		189		191											1120	771	94	155			460									255	165	255	160L-2/18.5
3		1680	300	901		257		259											1128	890	163	220			500											200L <sub>2</sub> -2/30		
4		1748		969		325		327											1432	943	197			540												200L <sub>2</sub> -2/37		
5		1856	325	1037		393		395											1664	1150	336			600												225M-2/45		
6		2040		1105		416		463												1873	1280	434			650												250M-2/55	
7		2017	350	1173	329	529	313	531	200	254	300	25	53	25	40	245	220	18		1941	1348	492																
8		2245		1241		597		599												2128	1484	603	322															
9		2315		1309		665		667												2262	1600	515	335															
10		2380	380	1377		733		735												2502	1760	694	402															
11		2500		1445		801		803												2502	1760	694	402															
12		2567		1513		869		871												2502	1760	694	402															
80DG50		2	1745	303	965		210		228											1294	892	105	175			530										310	200	275
	3	1865	235	1045		290		308											1405	951	145	215			620												Y225M-2/45	
	4	2060	370	1125		370		388											1584	1060	186	258			620												Y250M-2/55	
	5	2210		1205		450		468											1737	1130	224	303			670												Y280S-2/75	
	6	2340	400	1285		530		548											1948	1290	259	328			670												Y280M-2/90	
	7	2420		1365	388	610	355	628	220	270	340	30	50	25	45	265	245	23		2077	1400	474	307		750												Y315S-2/110	
	8	2490	395	1445		690		708												2262	1600	515	335			780												
	9	2910		1525		770		788												2502	1760	694	402															JK <sub>2</sub> 112-2/125
	10	2990		1605		850		868												2502	1760	694	402			540											JK <sub>2</sub> 113-2/150	
	11	3070	490	1685		930		948												2502	1760	694	402			780												
	12	3150		1765		1010		1028												2502	1760	694	402															
	100DG100	2	2550		1300		281		307											根据用户要求,可改变电机型号,供应泵与电机直联底座或不带底座。										568	396	550	YB315S-2/110					
3		2655		1400		389		415											We can change the type of motor. provide baseplate or no - baseplate according to the requests of uset										530	380	480	YB315M <sub>2</sub> -2/160						
4		2900		1516		497		523																								JK123-2/230						
5		3010		1624		605		631																								JK124-2/240						
6		3425		1732		713		739	310	410	510	43	67	40	65	320	290	27	/														JK132-2/290					
7		3500		1840		821		847																									JK133-2/360					
8		3670		1948		929		955																									JK134-2/440					
9		3870		2056		1037		1063																														
10		4350		2164		1145		1171																									JK500-2/500					



本公司拥有产品设计改进权，如有变动恕不另行通知。

烟台海汇船用泵业

烟台海汇船用泵业有限公司



烟台海汇船用泵业有限公司

烟台海汇船用泵业有限公司